



## HSL EMIRS Series

IR Sources for broad range Gas Analysis



LEISTER Microsystems

### Features:

- Thermal black body source
- Wide wavelength range (2-16  $\mu\text{m}$ )
- Fast electrical modulation
- High modulation depth
- No moving parts
- Low power consumption
- Long term stable output

### Applications:

- Infrared gas detection & monitoring (e.g. CO, CO<sub>2</sub>, NO<sub>x</sub>, SO<sub>x</sub>, anaesthetics)
- Photoacoustic gas detection
- Calibration sources

The IRSource is a micro-machined electrically modulated thermal infrared emitter with a compact package, no mechanical moving parts and a long lifetime.

The IRSource is based on a resistive heating element, integrated on a thin dielectric membrane. The low thermal mass permits a fast direct electrical modulation of the IR radiation.

A patented technology allows to manufacture highly reliable modulated IR sources with true black body characteristics and very high emissivity. This results in low power consumption and long life time with constant emission characteristics.

### Electrical/Optical characteristics (T<sub>c</sub>=25°C)

Parameter	Min	Typ	Max	Unit	Conditions
Cold Resistance	35	45	55	$\Omega$	
Hot Resistance		72		$\Omega$	450 mW
Electrical input power		450		mW	end of heating cycle
Operating voltage		5.7	6.3	V	450 mW
Operating current		80	90	mA	450 mW
Heating time constant		11		ms	
Cooling time constant		17		ms	
Peak emission wavelength		4.0		$\mu\text{m}$	450 mW
Emissivity	0.9	0.95			VIS to 15 $\mu\text{m}$
Lifetime (measured)		>40'000		hours	50% duty cycle, 30 Hz, 450 mW, ongoing
Heating area		2.1x1.8		mm <sup>2</sup>	
Case Temperature		47		°C	50% duty cycle, 30 Hz, 450 mW

### Package outline:

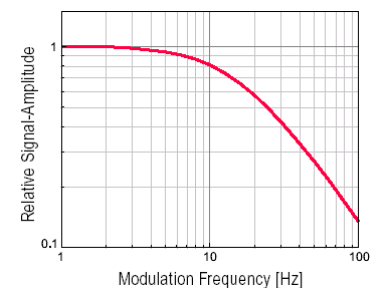
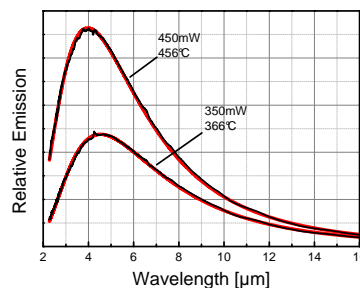
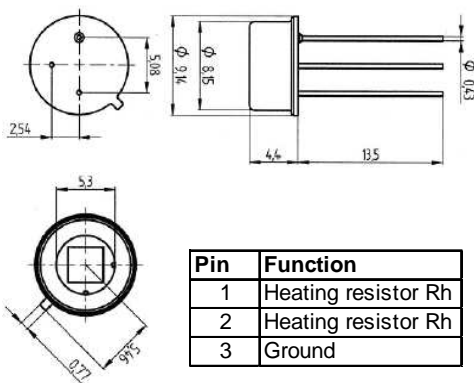

Square wave voltage, constant amplitude 50% duty cycle.

EMIRS200-40/53-0 IR source with cap, without window  
(A variety of window materials, filters and optical waveguides are optionally available).

Authorized distributor:

**HEIMANN Sensor GmbH**  
Grenzstr. 22  
D-01109 Dresden, Germany

**Contact / Customer Support**  
Phone 49 (0) 6123 60 50 30  
Fax 49 (0) 6123 60 50 39

**Internet**  
[www.heimannsensor.com](http://www.heimannsensor.com)  
e-mail: [info@heimannsensor.com](mailto:info@heimannsensor.com)