

### Features and Benefits

Heimann Sensor thermopile modules are non-contact thermometers comprising a high sensitive thermopile sensor and a signal conditioning circuit in the same housing. The thermopile modules can be supplied factory calibrated to a defined object temperature range, with or without internal temperature compensation reducing ambient temperature influence or even adjusted to fixed gain.

The devices are available in standard TO-39/TO-5 packages (HIS-series), mounted on printed circuit board (HTIA series) or as SMD packages (HCM-series).

Different types of signal conditioning ASICs can deliver analog output voltages or calculated temperatures on digital SM-Bus or PWM output.

This application note describes Heimann thermopile modules with 2 analog outputs for thermopile and temperature reference.

### Schematic

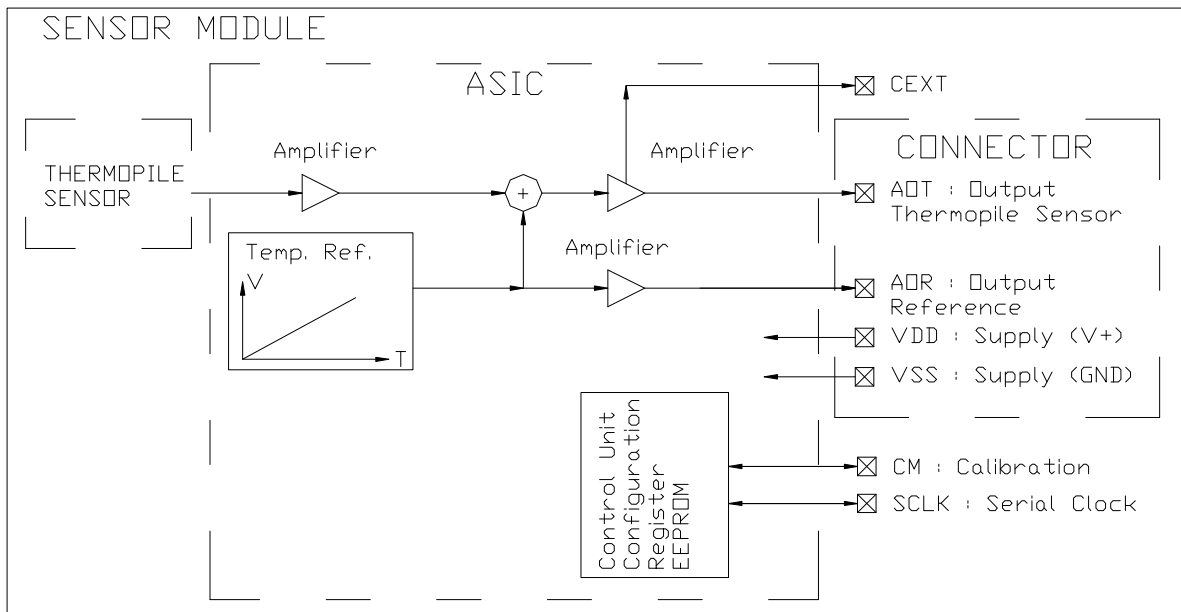

<i>connect</i>	<i>description</i>
AOR/TRO	analog output – temperature reference (AORt/TRO) or voltage reference (AORv)
AOT/TPO	analog output – object temperature related output voltage - AOTc (thermopile signal internal compensated by using integrated temperature reference) – AOTu/TPO (calibrated/fixed gain thermopile signal)
V+	power supply – positive supply voltage
V-	power supply – negative supply voltage , ground
CM/SCLK	use for factory setting

**Sensor Voltage on Output AOT/TPO**

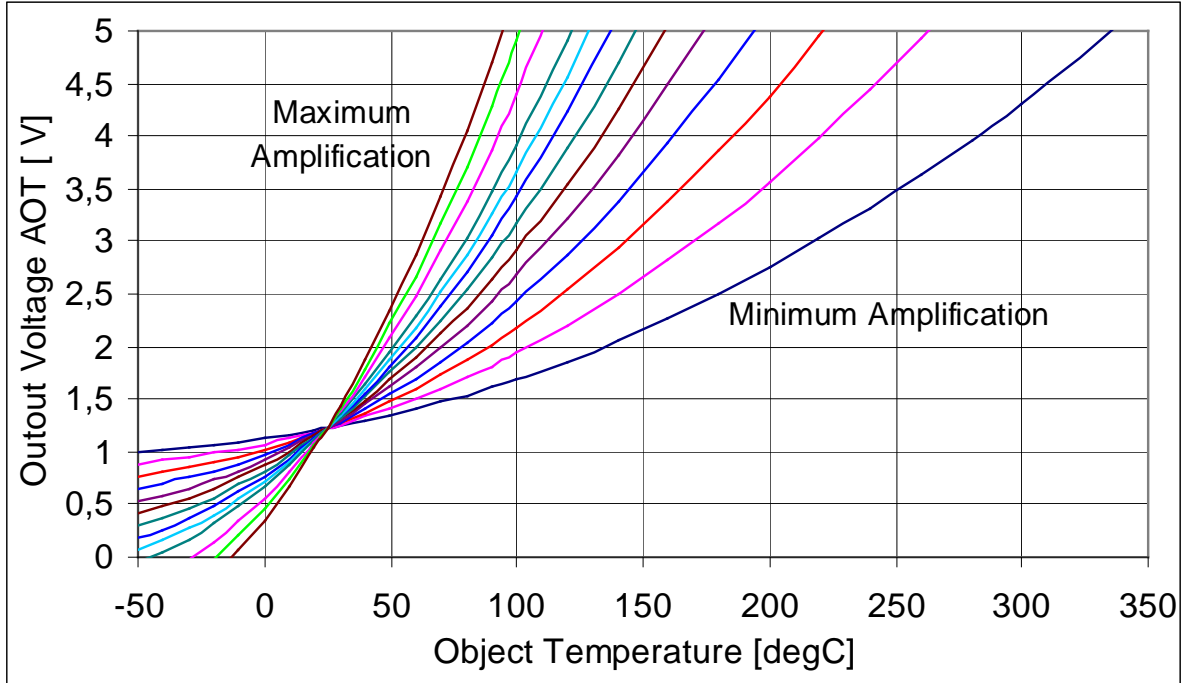

**Temperature Reference Voltage on Output AOR/TRO**

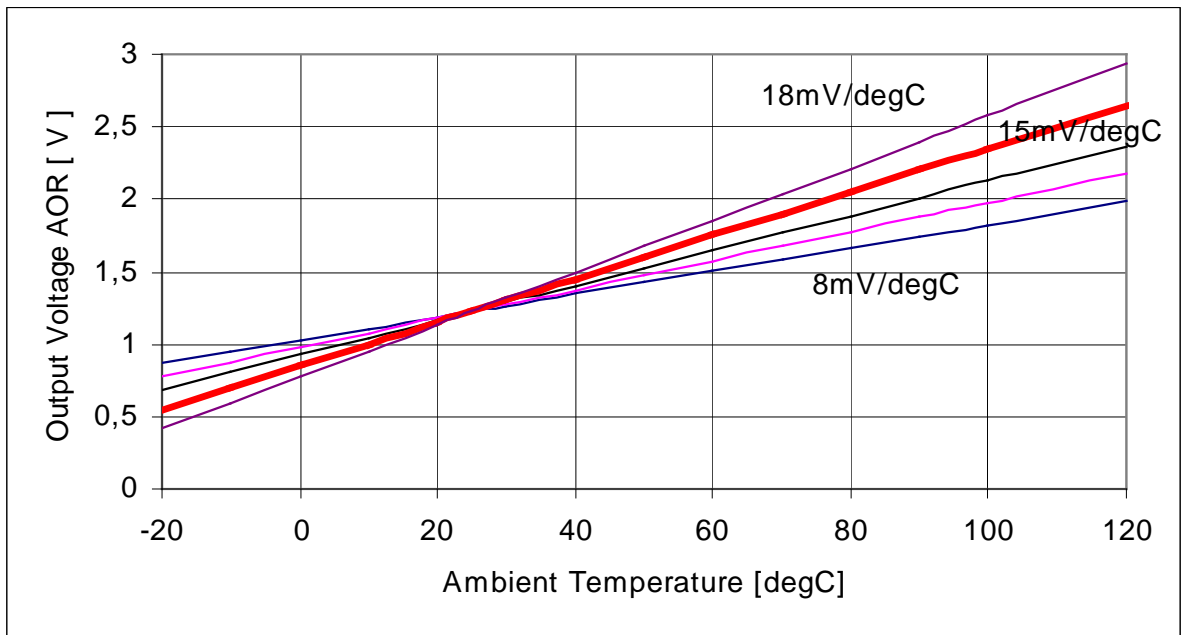

### Application Hints – Temperature Calculation and Compensation

The HEIMANN Sensor integrated module HTIA consists of a fast response thermopile sensor and an ASIC as specific integrated circuit for the signal processing and on chip calibration. The thermopile sensor converts the temperature radiation of an object surface to an electrical signal (voltage) by thermocouples (Seebeck effect). The sensor output voltage is related to the object temperature and emissivity (radiation) as well as to the sensor chip temperature (housing temperature) and surrounding temperature (radiation) by the following equation :

$$VS = K * \epsilon * ( TOn - TSn) \text{ at } TA=TS$$

- VS -> sensor output voltage
- K -> constant apparatus factor
- ε -> object emissivity
- TO -> object temperature
- TA -> ambient (surrounding) temperature
- TS -> sensor (housing) temperature
- n -> exponent to describe the temperature dependency of the signal voltage

The equation is simplified by the hypothesis of equal ambient and sensor temperatures. The exponent „n“ has the theoretical value of „4“ based on physical laws. But in the application practice it is an empirically determined exponent value mostly in the range of 3 .. 4 . The knowledge of the housing temperature is necessary to get the right object temperature from the sensor voltage.

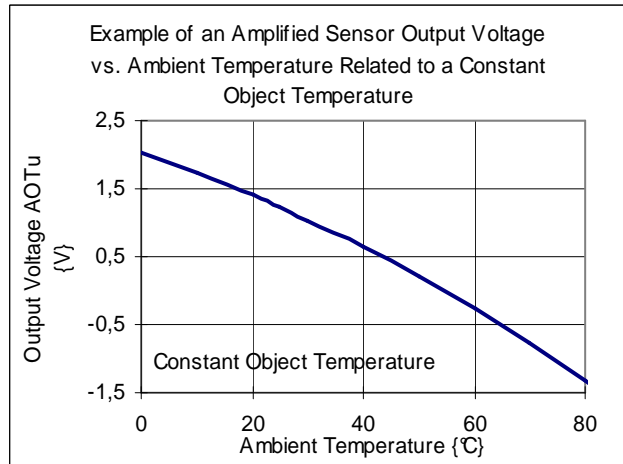
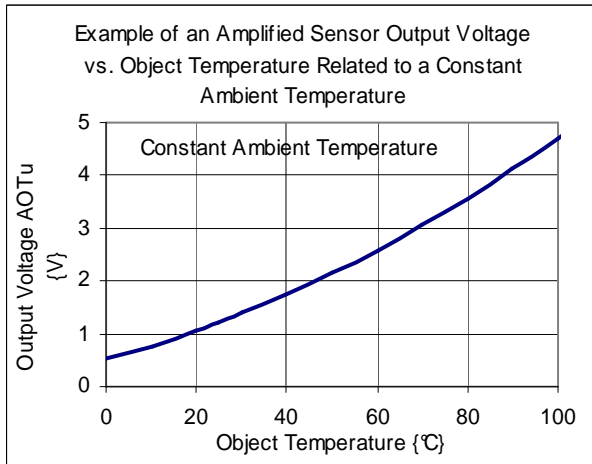

The integrated sensor module HTIA is designed to detect the housing temperature and to convert the temperature to a voltage.

By the multi-functionality of the integrated sensor module HTIA it is possible to use that voltage for an internal (on chip) ambient temperature compensation which makes the output voltage of the sensor module widely independent from ambient temperature variations within a range of about 40°C. The achievable accuracy is shown on the picture.

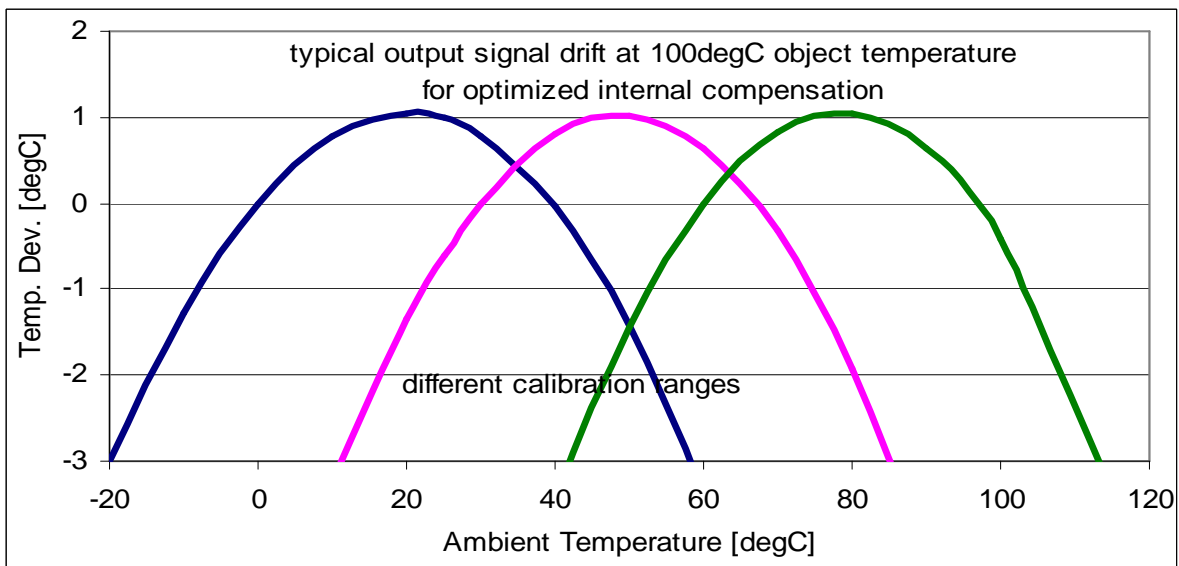

For higher accuracy requirements the multi-functional sensor module can output the amplified and calibrated sensor voltage separated from the linear on-chip temperature reference voltage. With it the ambient temperature compensation can be simply done combined with the object temperature calculation by the external microcontroller used in most applications. The following equations and procedures can be used for the calculation of the object temperature independent from the ambient temperature with sufficient accuracy for most applications.

#### Base Function

Vobj (V): sensor object voltage  
 K : constant apparatus factor  
 ε : emissivity of the object  
 Tobj (K): object temperature (Kelvin)  
 Tamb (K): sensor (ambient) temperature (Kelvin); The equation is simplified by the hypothesis of equal ambient Tamb and sensor temperatures Ts.  
 n: exponent, empirically determined, in sensor practice mostly in the range 3 to 4

$$V_{obj} = K * \epsilon * (T_{obj}^n - T_{amb}^n)$$

$T_{amb} = T_{sensor}$

#### Experimental Determined Factors

In a first approximation the constant factor "K" and exponent "n" based on the Heimann Sensor measuring data can be used. The verification is recommended by an application test. In most cases an exponent of 4 is sufficient for the required temperature tolerance, which simplifies the calculation.

$$K = \frac{V_{obj}}{\epsilon * (T_{obj}^n - T_s^n)}$$

Function for Object Temperature Calculation with Temperature Compensation

$$T_{obj} = \sqrt[n]{\frac{V_{obj}}{K * \epsilon}} + T_s^n$$

The uncompensated sensor output voltage  $V(AOT_u)$ , measured at the output AOT, is consisting of object based signal voltage  $V_{obj}$  and reference voltage  $V_{ref}$  :

$$V_{obj} = V\{AOT_u\} - V_{ref}$$

Internal temperature gradients generate additional offset voltages  $V_{offs}$  depending on application influences :

$$V_{obj} = V\{AOT_u\} - V_{ref} + V_{offs}$$

The temperature generated offset can be determined by an output signal test at  $T_{obj} = T_{amb}$ . Calculation of the ambient (sensor) temperature using the sensor output AOR :

$$T_s = 1/S_T * (V\{AOR_t\} - V\{AOR_t@25\}) + 298.15K$$

Ts: sensor temperature  
 $S_T$  (V/K): temperature sensitivity of the internal temperature reference  
 $V\{AOR_t\}$  (V): measured temperature output voltage at output AOR  
 $V\{AOR_t@25\}$ (V): temperature output voltage at 25°C (298.15K) -> test certificate

For first tests the object temperature calculation can be done by the mentioned calculation procedure using an application factor and exponent derived from the Heimann Sensor sample data and based on Heimann Sensor test equipment.

All test data are typical related to a defined emissivity of 100%. The emissivity variation can be considered by the factor  $\epsilon$ .

Another ways for the object temperature calculation with ambient temperature compensation can be performed using look-up tables or polynomial regression equations.

But by the large number of physical affects influencing the non-contact temperature measurement, it is difficult to have the best initial adjustment for the different applications. In detail the measuring is influenced by the object emissivity and its variation, optical ratios (field of view, object size, measuring distances), the ambient and object temperature ranges, the adjustment of the ambient temperature compensation as well as unstable (dynamic) ambient temperature conditions. For that reason the object and ambient temperature to output voltage relation needs to be measured on application conditions.

For most applications an optimized solution can be found and fixed for a serial production. Don't hesitate to contact HEIMANN Sensor for support to use our long-time experience in infrared sensors and sensor modules.

**Application Hints – Gas Detection**

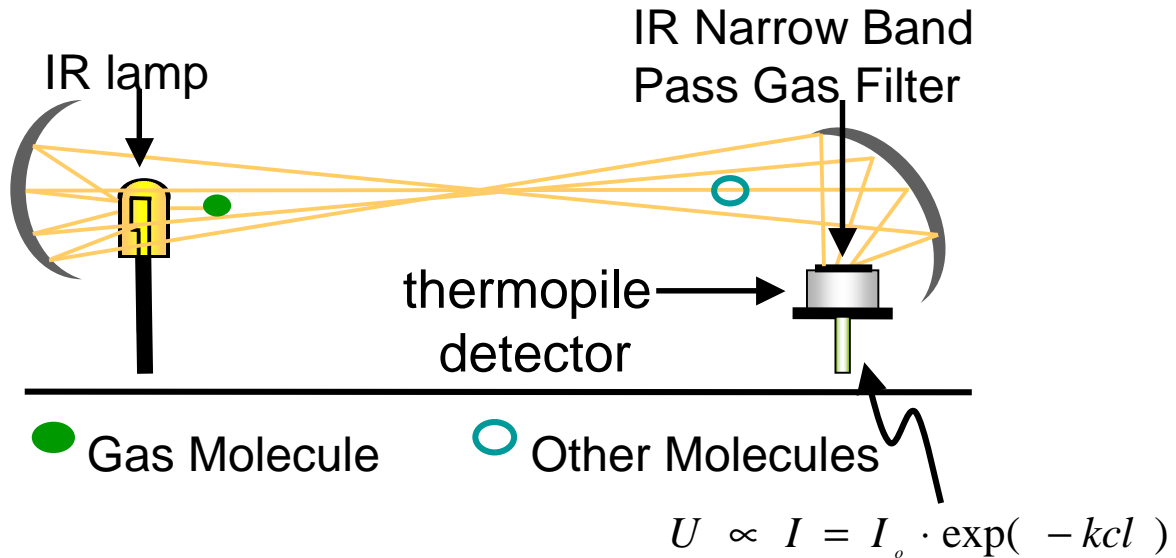

The gas concentration can be measured by monitoring the absorption of an infrared light beam. The base equation for gas concentration measurement in the infrared way is Beer's law :

**$I = I(0) \cdot \exp(-k \cdot c \cdot L)$**

- I -> radiant flux at the point of measurement
- I(0) -> base radiant flux of the test system without gas absorption
- k -> constant (gas and filter specific)
- L -> measuring distance
- c -> gas concentration

The radiant flux is proportional to the output voltage of the sensor module :  $U/U(0) \sim I/I(0)$  . A special infrared light source is used to generate the radiant heat. The infrared source needs to be pulsed to eliminate parasitic temperature influences. The temperature reference output (housing temperature) of the sensor module can be used to compensate ambient temperature drift effects.

**Available Infrared Filter for Gas Detection**

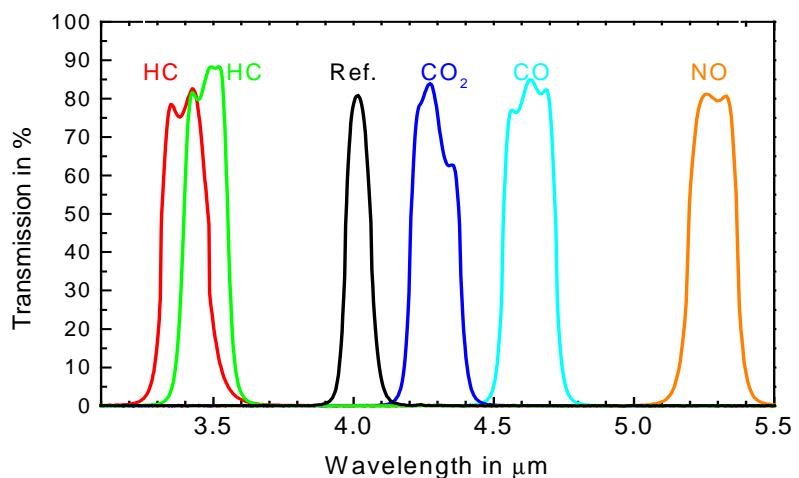

HEIMANN Sensor GmbH  
Grenzstr. 22  
D-01109 Dresden  
Rohrbergstr. 7  
D-65343 Eltville

Managing Director  
Dr. J. Schieferdecker  
Reg. at District Court  
Dresden HRB20692  
VAT-ID DE813444739

Internet: [www.heimannsensor.com](http://www.heimannsensor.com)  
Mail: [info@heimannsensor.com](mailto:info@heimannsensor.com)  
Phone 49 (0) 6123 60 50 30  
Fax 49 (0) 6123 60 50 39

## Ordering Information

Our thermopile sensors with integrated signal processing are designed to reduce application effort in development and production. They are divided into 2 main groups of calibrated thermopile modules and fixed gain integrated sensors. A broad range of housings is available from transistor outline packages (TO) through printed circuit board to SMD packages.

Please provide following information to support type selection if required:

- required sensor package, space limitation
- object and ambient temperature ranges
- if possible object (surface) emissivity
- temperature accuracy and resolution
- field of view or object size and measuring distance
- special environmental conditions
- requested speed of response
- filter transmission range if

Don't hesitate to contact Heimann Sensor customer support at

Tel: +49 6123 605030

e-mail: [Info@heimannsensor.com](mailto:Info@heimannsensor.com)

For more information on our products please visit our website:

[www.heimannsensor.com](http://www.heimannsensor.com)

## Liability Information

This document is subject to change without notice.

Changes or modifications which haven't influence to the performance and/or quality of Heimann Sensor devices haven't to be announced to customers in advance.

Customers are requested to consult with Heimann Sensor representatives before the use of Heimann Sensor products in special applications where failure or abnormal operation may directly affect human lives or cause physical injury or property damage. The company or their representatives will not be responsible for damage arising from such use without prior approval.